

# CASE STUDY OF 9M HIGH GEOGRID REINFORCED SEGMENTAL BLOCK WALL IN SOUTHEAST QUEENSLAND

Barry Wai-Choo Kok<sup>1</sup>, Jeroen Berends<sup>2</sup>, Jia Xie<sup>3</sup> and Martin Silec<sup>4</sup>  
<sup>1&2</sup>Principal Geotechnical Engineer, <sup>3</sup>Geotechnical Engineer,  
GeoInventions Consulting Services, Brisbane, Queensland, Australia.  
<sup>4</sup>Managing Director,  
Concrib Pty Ltd, Brisbane, Queensland, Australia.

## ABSTRACT

A 9.0m high geogrid reinforced segmental block wall was designed and constructed in Bethania, southeast of Queensland in 2012. It is currently the highest geogrid reinforced segmental block wall in Australia using the Stone Strong<sup>®</sup> system. In-situ highly to moderately weathered meta-siltstone and meta-sandstone were adopted as reinforced fill of the wall. Due to the significant depth of residual fill beneath the wall, the wall was designed to be founded on a continuous raft footing supported by drilled concrete piers. At critical sections over the wall length, differential height tiered walls supporting a heavily loaded access ramp were designed. This paper describes the design methodology based on large scale pull-out test results and AS4678:2002 guideline is adopted to assess the stability and deflection of the wall. Finite element and limit equilibrium analyses were performed to verify critical design sections, including sensitivity check on key design parameters from in-situ materials. Construction procedures and methodology to meet the design criteria in achieving the project requirements will be discussed.

## 1 INTRODUCTION

### 1.1 PROJECT BRIEF

A new industrial and commercial development at Glasson Drive, Bethania required very high reinforced soil structures, some in excess of 9.0m on which a new Bunnings warehouse was to be built. The design utilized large Stone<sup>®</sup> Strong blocks with encompassed polyester geogrids extending back into the reinforced soil zone for stability. To maximize space and land value, the wall was designed to utilize a face batter of 1(H):18(V). Extensive stability analysis for various heights of walls including a two-level tiered wall was conducted. The most critical section was the tiered wall which had a lower wall height of 4.0m and a higher wall height of 7.0m in height. Between these tiered walls was an access road for heavy loaded trucks which delivered stock to the Bunnings warehouse. Finite element analysis was also conducted to measure wall deflections over time. Over 2,500m<sup>2</sup> of walling was constructed using over 18,000m<sup>2</sup> of geogrid.

### 1.2 STONE<sup>®</sup> STRONG SYSTEM

The Stone<sup>®</sup> Strong system was first introduced in the United States of America in the year 2001 and was launched in Australia in 2011 with the first wall being constructed for the Gold Coast City Council by Concrib Pty Ltd. The Stone<sup>®</sup> Strong System consists of large modular precast hollow blocks suitable for gravity retaining structures up to 5.0m and RSS walls in excess of 15.0m. The standard 24SF block has a chiselled granite face area of 2.24m<sup>2</sup> and has a mass of 2722kg. The smaller 6SF block has a 0.56m<sup>2</sup> face area and has a mass of 680kg. Each block is manufactured using a minimum concrete strength of 40MPa at 28 days and are internally backfilled with aggregate to provide additional retaining wall mass.

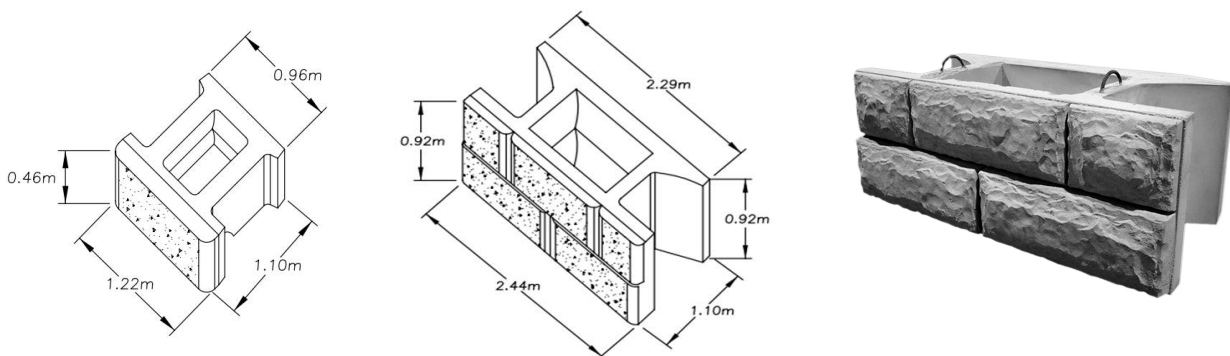

Figure 1: Typical Stone<sup>®</sup> Strong blocks dimension

2 REVIEW OF CURRENT DESIGN PRACTICES

The National Concrete Masonry Association (NCMA) and Federal Highway Administration (FHWA) design guidelines adopt different methodologies regarding the wall behaviour. Fundamental principles of each design approach are discussed under the subsequent subheadings:

2.1 NCMA DESIGN APPROACH

The NCMA Design Manual for Segmental Retaining Walls provides specific guidelines for tiered walls with respect to spacing between the tiers and the effect of the upper tier wall on the internal and external stability of the lower tier wall. When the setback distance (D) of the upper tier wall (H<sub>2</sub>) is greater than the height of the lower tier wall (H<sub>1</sub>), the internal design is not affected by the upper tier wall. However, this is not true for Global Stability.

The NCMA design approach also replaces the upper tier with an equivalent surcharge (q) of which its magnitude is determined according to the offset distance. External and internal stability calculations for the lower tier are performed assuming the lower tier being a single wall under the equivalent surcharge. The upper tier is designed as if it were a single wall without taking into consideration of the possible interaction between the upper and lower tiers as described in following figure. As for a single wall, the local stability calculations for the connection failure, overturning and sliding are required to be checked for both tiers.

The NCMA methodology also applies that the reinforced and retained soils are cohesionless and that the apparent cohesive strength of these soils are ignored, which is a conservative assumption for the design. It also applies a constant infinite back slope at a constant infinite angle.

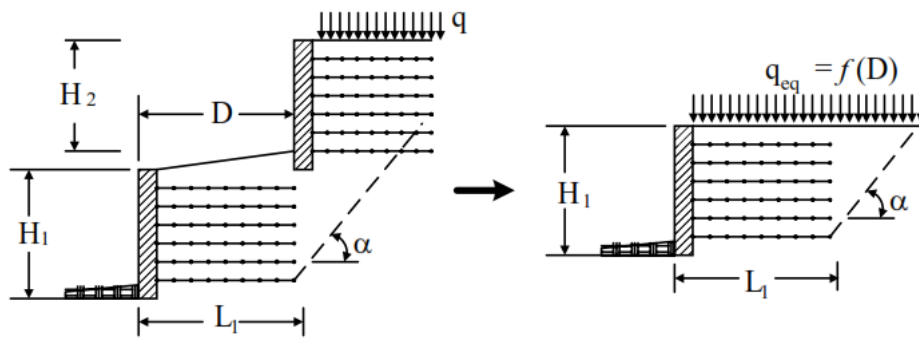

Figure 2: NCMA design concept of tier wall system (Courtesy of C.Yoo, 2004)

2.2 FHWA DESIGN APPROACH

The concept of FHWA design guideline describes the method in determining the lower and the upper reinforcement lengths (L<sub>1</sub> & L<sub>2</sub>) respectively that satisfy external stability requirements based on the offset distance (D) together with the lower (H<sub>1</sub>) and upper tier (H<sub>2</sub>) height. The design methodology is governed by the following 3 scenarios.

- Scenario 1 – if  $D > H_1 \tan(90^\circ - \phi)$ , each tier is independently designed.
- Scenario 2 – if  $D \leq 1/20(H_1 + H_2)$ , design as single element of  $H_{total} = H_1 + H_2$
- Scenario 3 – if  $D \geq 1/20(H_1 + H_2)$ , reinforcement length for lower tier wall shall be  $L_1 \geq 0.6 * H_1$ ; reinforcement length for upper tier wall shall be  $L_2 \geq 0.7 * H_2$

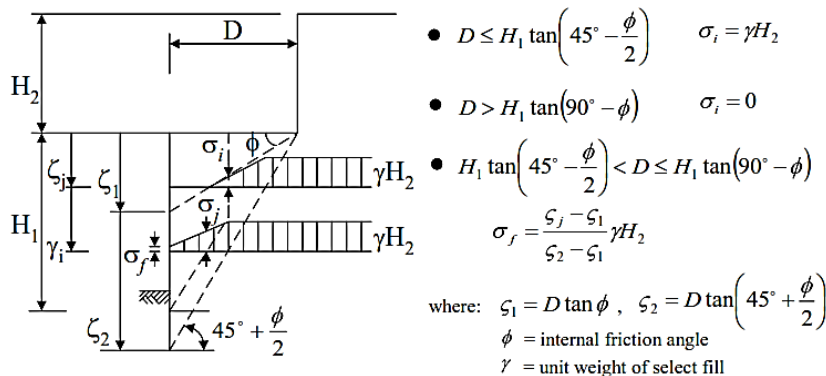

Figure 3: Calculation model of vertical stress distribution due to upper tier wall (Courtesy of C.Yoo, 2004)

### 3 PROJECT DESIGN METHODOLOGY

#### 3.1 REGIONAL AND LOCAL GEOLOGY

Based on the Geological Survey of Queensland geological map, the site can be expected to be underlain with rocks of the Neranleigh-Fernvale Beds. The Neranleigh-Fernvale Beds typically comprises interbedded, folded and sheared greywacke and sandstone, chert with mudstone, shale and occasionally weakly metamorphosed phyllite. Lithic sandstone that specifically has a fine grained recrystallised clay and silt is termed greywacke. Typically sandstone and greywacke are the prevalent mapped units in this area.

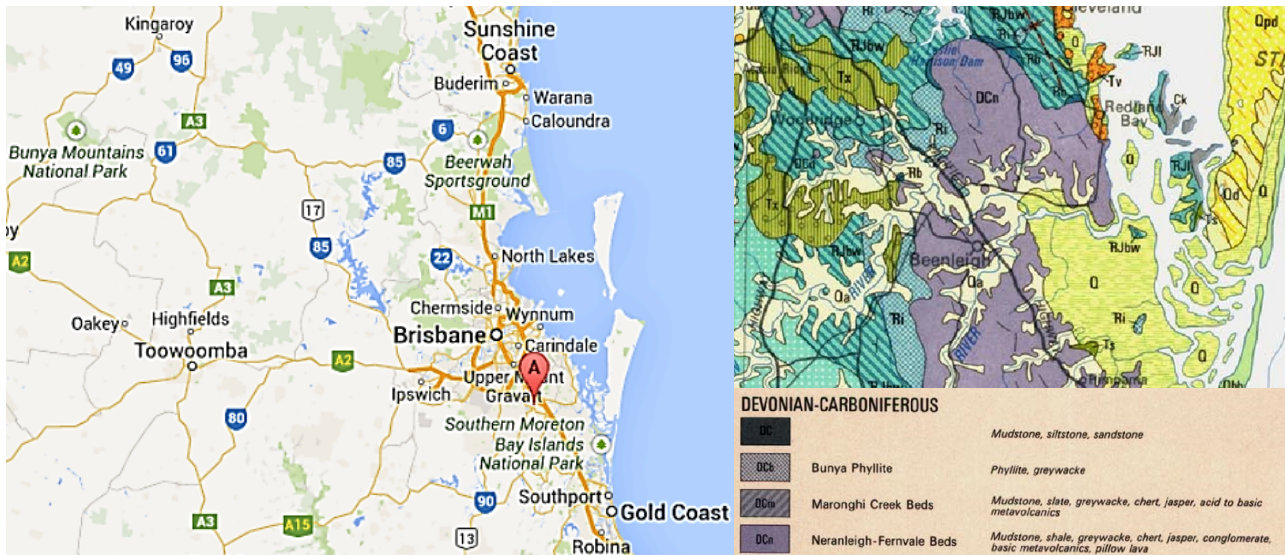

Figure 4: Location map and regional geological map of southeast Queensland

Site investigation results indicated existing ground conditions comprising of a cut and fill platform. The platform consisted of highly to moderately weathered meta-siltstone and meta-sandstone from the Neranleigh Fernvale Beds (NFB) formation overlain by a layer of 0.5m to 1.0m natural medium dense to dense clayey sand and very stiff to hard sandy clay.

#### 3.2 ADOPTED DESIGN PARAMETERS

Prior to stability analysis, representative properties must be assigned to each material used in the Stone<sup>®</sup> Strong wall. Each material was characterized by the friction angle, cohesion and representative bulk unit weight as shown in the table below:

Table 1: Soil properties adopted in design

Material Properties	Block Infill Aggregate	Retained Soil	Foundation Soil	Controlled Fill
Angle of internal friction, $\phi'$ (deg)	35	28	35	35
Bulk unit weight of soil, $\gamma$ (kN/m <sup>3</sup> )	20	19	21	21
Cohesion, $c'$ (kPa)	0	5	10	10

Minimum embedment depths were taken as H/20 as per RMS R57 code for the design of reinforced soil walls. An allowable bearing capacity of the foundation which consists of meta-sandstone and meta-siltstone was specified to be 150kPa for walls up to 4.0m in height and 200kPa from walls between 4.0m and 10.0m in height. To prevent a punching failure due to the high vertical stress, the foundation soil was compacted prior to casting a 150mm concrete footing reinforced with SL81 mesh as a foundation beneath the first row of Stone<sup>®</sup> Strong blocks.

Uniaxial polyester geogrids Miragrid GX200 and Miragrid 10XT were adopted as pull-out reinforcement in the design. Whilst geogrid reinforcement lengths are controlled by external and internal pullout capacity calculations, a minimum reinforcement length of 0.6H + 1.0m was adopted as per RMS R57 design code. In the limit equilibrium approach, the long term design strength of the polymeric reinforcement is determined by applying partial factors for durability,

installation damage and creep for a 60 year design life. The long term design strengths adopted in the design for GX200 and 10XT were 123.7kN and 70.4kN respectively.



Figure 5: Installation processes of Stone Strong blocks wall and geogrid reinforcement

The Stone<sup>®</sup> Strong blocks were internally backfilled with 20mm aggregate to provide additional retaining wall mass and the aggregate acts as an internal drainage layer.  $Q_{100}$  flood level and existing groundwater level were located well below the toe of the Stone<sup>®</sup> Strong wall as not to influence the stability of the structure.

Light compaction equipment was used within 1.0m behind the wall facing and a 20kPa uniformly distributed load was applied as surcharge in the stability analysis behind the Stone<sup>®</sup> Strong wall to accommodate for the heaviest loading condition during the construction and operation of the warehouse.

Whilst horizontal impact loads from crash barriers were not provided by the contractor and principal consultant, it is understood that there is a provision in design to install concrete traffic crash barriers after the completion of the wall. Therefore, an impact load of 5kN/m acting on a traffic barrier was included in the design based on previous experience of highway design projects.

The design also adopted a seismic acceleration coefficient of 0.06g for the Brisbane area as per AS4678-2002 Table 11.

### 3.3 IN-SITU MATERIALS

It is widely accepted that reinforced soil walls need to contain good quality fill such as sands and gravels that are well graded. For example, the RMS R57 (2012) specification states that soil properties should be granular and contain less than 15% fines. However, for many projects the ability to use in-situ materials not meeting the relevant specifications would result in significant cost savings. In the case of this project, highly to moderately weathered meta-sandstone and meta-siltstone was excavated from the site and crushed to a specific grading to adopt as reinforced fill behind the Stone Strong<sup>®</sup> walls. A particle size distribution graph is shown in Figure 6.

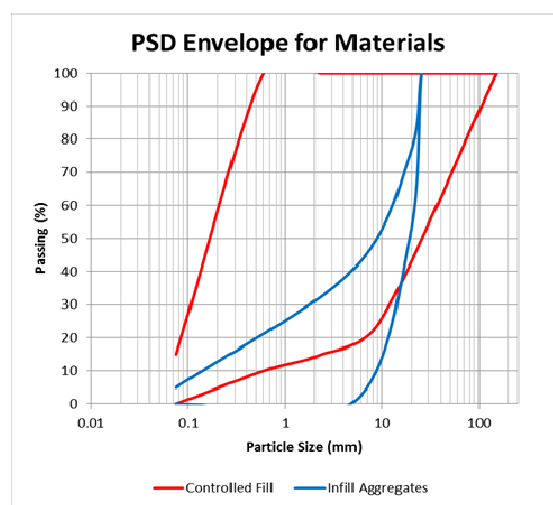

Figure 6: Particle sieve distribution of controlled fill and infill aggregates

Laboratory direct shear tests were conducted on the crushed in-situ meta-sandstone and meta-siltstone materials intended to be adopted as reinforced fill. The test results indicated a peak and residual internal friction angle of 38° and

28° respectively. The test results also indicated an extremely high peak and residual cohesion of 33kPa and 26kPa respectively. A nominal drained cohesion of 5kPa was adopted in the design based on the recommendations of AS4678:2002.

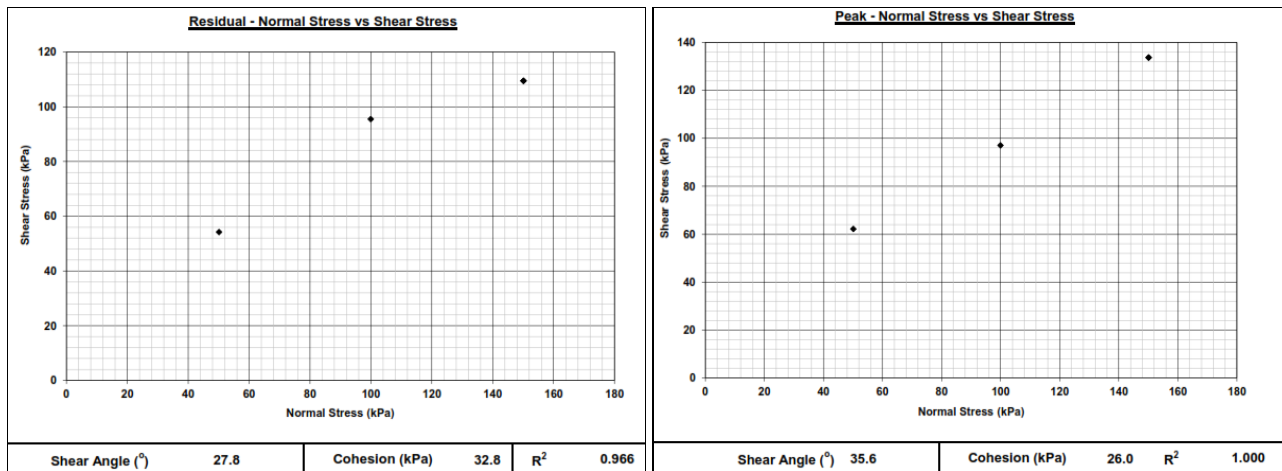

Figure 7: Direct shear test results for in-situ meta-sandstone and metasiltstone

The reinforced fill was compacted in 300mm layers and density tests were performed for every 400m<sup>3</sup> of reinforced fill placed. According to AS4678:2002, any soil or rock placed at a site in a controlled fashion shall be compacted to 98% of the maximum dry density (MDD). All test reports for materials tested on site reported density ratio's greater than 98%.



Figure 8: Construction processes of adopting in-situ materials

### 3.4 LIMIT EQUILIBRIUM APPROACH

Limit-equilibrium approaches are routinely adopted for the design and analysis of reinforced segmental retaining walls. Stability analysis of the Stone<sup>®</sup> Strong wall was conducted to ensure that the minimum design criteria were met in terms of the NCMA, FHWA and RMS R57 design guidelines.

Limit equilibrium software SlopeW was adopted to justify an adequate factor of safety for the proposed reinforced geogrid wall arrangement. The minimum shear strength required along a potential failure surface to maintain stability is calculated and then compared to the available shear strength of the soil. The factor of safety is assumed to be constant along the entire failure surface. The factor of safety for global stability is  $FOS \geq 1.50$ .

To ensure that there is sufficient connection strength between the geogrid reinforcement and the Stone<sup>®</sup> Strong blocks to prevent rupture or slippage of the reinforcement due to the applied tensile force, calculation of interface shear capacity and connection capacity developed between the Stone<sup>®</sup> Strong blocks and the geogrid reinforcement were taken into account within the design.

Instead of adopting the conventional monolithic model for the Stone<sup>®</sup> Strong wall, a new constitutive model is developed based on the large scale direct pull-out test results carried out in United State, 2004. The normal stress versus shear stress relationship is modelled to simulate the shear capacity of reinforcement at different wall heights.

### 3.5 FINITE ELEMENT ANALYSIS

Geosynthetic reinforcement materials are manufactured from high density polyethylene or polyester. These materials are visco-elastic-plastic materials and hence offer challenges in numerical modelling. In practical terms these materials have properties that are strain level and load rate dependent. In geosynthetic practice, stiffness in units of force over length (kN/m) is used since cross-section area and thickness of these materials varies and is hence problematic. In most numerical codes this value must be converted to a modulus (E) for an equivalent solid material with constant area and thickness.

Commercial finite-element software PLAXIS was used for analysis. In the finite-element modelling, the wall components were carefully modelled including the concrete pier foundation. A refined mesh was adopted to fully account for the construction procedure. No interface was introduced between the soil and the reinforcements assuming no slip between the backfill and the reinforcements. The objective of the analysis is to justify the recommended maximum allowable movement of the connections to minimize wall face deformation to 50mm as per AS4678-2002.

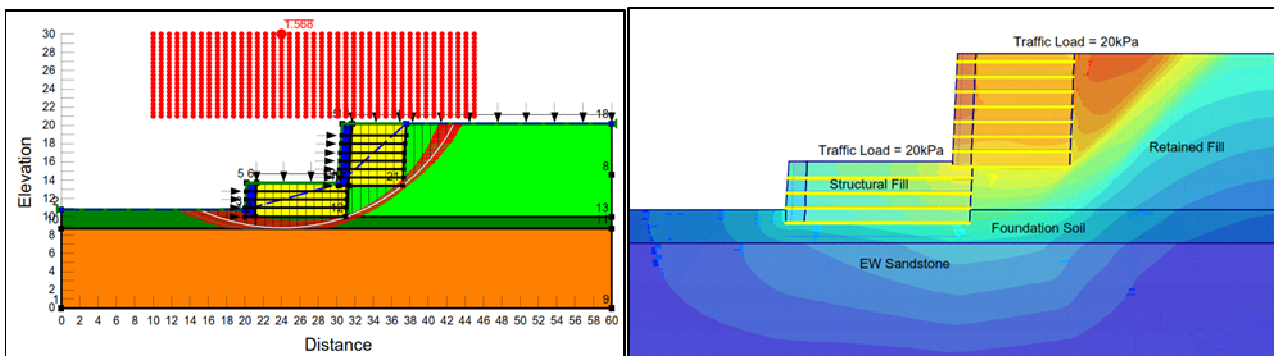

Figure 9: Analysis outputs of limit equilibrium and finite element

## 4 DESIGN & CONSTRUCTION CHALLENGES

### 4.1 DESIGN CHALLENGES

The western wall required an access ramp which allows trucks for delivery to the new Bunnings warehouse. The lower tier wall is designed to accommodate the access ramp and the upper tier wall with the new warehouse as surcharge. The lower tier wall heights ranged between 4.0m and 4.8m in height whilst the higher walls ranged between 1.0m and 8.0m in height. The influence from the upper tier wall on the lower tier wall had to be analysed and the cross section below illustrates the most critical design section where a 4.0m lower tier wall and 8.0m upper tier wall are located:

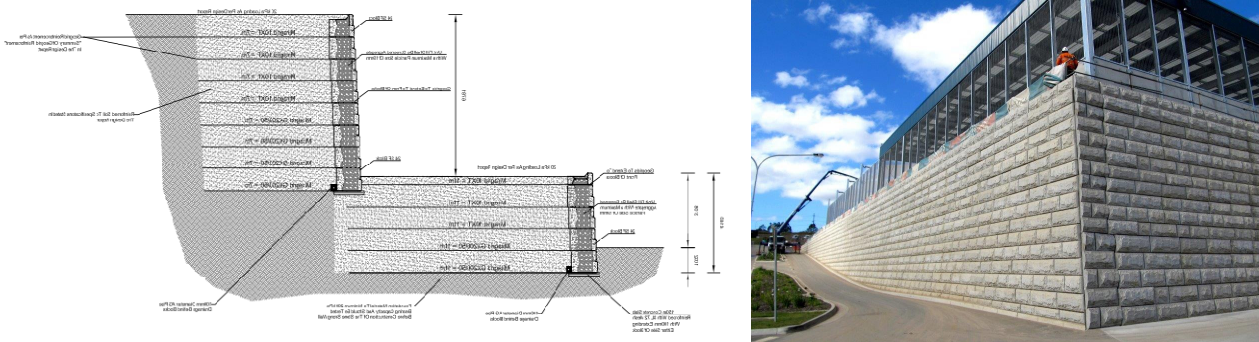

Figure 10: Critical cross section of the lower and upper walls

As geogrid reinforcement could only be placed between the Stone Strong® blocks, this limited the vertical spacing of the geogrid reinforcement to 0.46m (6SF block) or 0.92m (24SF block). To accommodate this requirement, higher strength of geogrid reinforcement had to be used to increase the overall pull-out strength.

During the construction of the critical tiered walls, a design revision was issued by the Principal Engineers to increase the fill heights for the lower tier walls by a maximum 2.2m. This revision increased the height of lower tier walls from 4.0m to 6.0m. As the walls were constructed midway, the geogrid reinforcement lengths could no longer be increased to provide extra stability due to the increased surcharge. Reanalysis of the new walls decreased the original factors of safety to FOS=1.55. Only one wall at the end of the access ramp which was to be a single wall increased in height from

5.0m to 7.0m. This decreased the factor of safety to  $FOS < 1.50$ . The remedial design approach was to increase the geogrid reinforcement length from 7.0m to 10.0m for the top three blocks only. The reinforced fill was altered to high frictional Type 2.3 base material to act as a layer of uniform soil mattress which aims to distribute the additional surcharge loading and higher shear resistant. Reanalysis of this wall provided an adequate factor of safety of 1.55 which met the design requirement as shown in Figure 11.

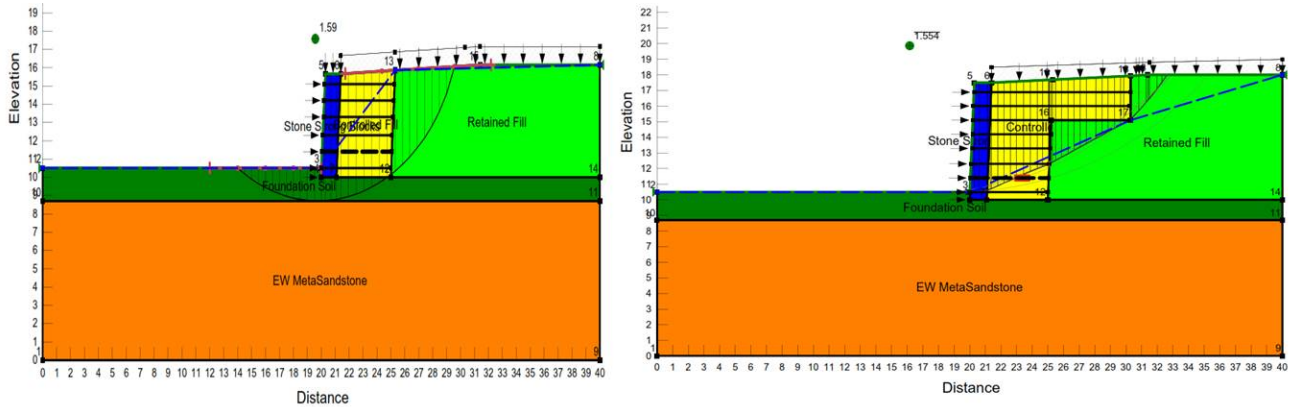

Figure 11: Analysis outputs of the original design and the reanalysis after the fill heights were increased

## 4.2 CONSTRUCTION CHALLENGES

The initial site survey did not indicate a 1.0m high boulder wall which built along the western boundary of the property. As this existing boulder wall was inadequate to provide the stability to retain neither the new retaining walls nor the new access ramp to the warehouse, the boulder wall was removed and the lower tier walls were increased in height.

Dynamic Cone Penetration (DCP) tests were conducted to measure the allowable bearing pressures of the foundation prior to casting the concrete footing. Some DCP results indicated inadequacy to meet the required allowable bearing pressures on the lower walls and the required founding material was located between 0.5m to 0.8m below the proposed bottom of wall level. As an alternative to excavate the weaker clayey sand layers which would increase the height of the wall and costs, the Stone<sup>®</sup> Strong wall was founded on 450mm diameter unreinforced in-situ concrete piers spaced at 1.5m centres which were installed to a minimum depth of 1.0m into the competent founding material.

## 5 RECOMMENDATIONS AND CONCLUSIONS

An overview of the project at completion provides the following recommendations and conclusions with particular emphasis on achieving goals set at the beginning of construction:

- The setback of the upper tier wall was about twice the height of the lower tier wall which according to the NCMA & FHWA design concept shall have no effect on the lower tier wall. Limit equilibrium results indicated the reinforcement lengths required are more than the height of lower tier wall ( $H_1$ ) to accommodate the requirement of Global Stability due to the significant contribution of surcharge from the upper tier wall ( $H_2$ ). In the critical section where  $H_2 \geq 2 \cdot H_1$ , the reinforcement length required is approximately equal to the setback distance ( $D$ ).
- The successful use of crushed in-situ meta-sandstone and meta-siltstone as reinforced fill, which was not based purely on frictional fills, provided a significant cost saving to the client. Regular monitoring of reinforced fill placement and field testing are required to ensure that the correct grading and necessary compaction are achieved on site.
- The innovative Stone<sup>®</sup> Strong wall could be constructed several blocks high with the geogrid reinforcement already installed between the blocks. This allowed for continued placement of blocks and geogrid whilst the reinforced fill was being placed in other locations. This construction method allowed 2500m<sup>2</sup> of Stone<sup>®</sup> Strong blocks and 18000m<sup>2</sup> of geogrid to be installed within a period of four months.
- The vertical spacing of the geogrid reinforcement is limited to the block heights of 0.46m or 0.92m which is slightly more than the vertical spacing recommended in the design codes. Higher strength geogrids need to be adopted in the design to improve internal stability.

- Critical sections in these types of projects should not be optimized to the boundary of  $FOS \geq 1.50$  as construction issues may require the design to change midway through the project. Some margin should be provided in the factor of safety to allow for these construction changes.
- Regular on-site supervision is necessary to validate geogrid reinforcement lengths as per the design and to prevent damage of the geogrid reinforcement. Drop heights of fill shall be limited to 300mm and no construction machineries or plant shall be allowed to travel over the geogrid reinforcement.

## 6 ACKNOWLEDGEMENTS

The authors of this paper would like to acknowledge and thank Bunnings Warehouse, Walker Corporation, CATCON, Stone® Strong Systems and Concrib Pty Ltd for their assistance and kind permission to publish this paper. We look forward to future collaboration with many of these individuals in our effort to implement innovative and useful infrastructure related technology.

## 7 REFERENCES

- Bathurst, R.J. and Simac, M.R. (1994) *Geosynthetic Reinforced Segmental Retaining Wall Structures in North America*. Keynote lecture, 5<sup>th</sup> International Conference on Geotextiles, Geomembranes and Related Products, Singapore, September 1994.
- Bathurst, R.J. Huang, B. and Hatami, K. (2008) *Numerical Modelling of Geosynthetic Reinforced Retaining Walls*. The 12<sup>th</sup> International Conference of International Association for Computer Methods and Advances in Geomechanics (IACMAG), pp. 4071-4079, India, October 2008.
- Collin, J. (1997) *Design Manual for Segmental Retaining Walls*. 2<sup>nd</sup> Ed. National Concrete Masonry Association (NCMA), Virginia, USA.
- Geo-Slope. (2012) *Stability Modelling with SLOPE/W – An Engineering Methodology*. GEO-SLOPE International, Calgary, Alberta, Canada.
- PLAXIS. (2012) *PLAXIS 2D Version 9.0 - Finite Element Code for Soil and Rock Analysis*. Delft, Netherlands: A. A. Balkema Publishers.
- Roads & Maritime Services, NSW (2012), *R57 QA Specification - Design of Reinforced Soil Walls*.
- Stone® Strong System. *Engineering Manual*. Nebraska, USA, 2010.
- Yoo, C.S. (2004) *Design of a Geosynthetic Reinforced Segmental Retaining Wall In a Tiered Arrangement – Use of Numerical Modelling as a Design Aid*. 3rd Asian Regional Conference on Geosynthetics, GeoAsia, Seoul, Korea, pp. 173-182.
- Yoo, C.S. and Lee, K. M. (1999) *Investigation on Behaviour of Reinforced Segmental Retaining Wall*. Journal of Korean Geotechnical Society, Vol. 15, pp. 53-62.
- Yoo, C.S. and Kim, J. S. (2002) *Behaviour of Soil-Reinforced Retaining Walls in Tiered Arrangement*. Journal of Korean Geotechnical Society, Vol. 18, pp. 61-72.